



A Donald **BASIL** Company

# Life Science Solutions

*The LYNX mission is to provide Animal Care Washing Systems of the highest standards, quality, and reliability in the industry. Our service and customer care will be unmatched*

## ***Model 710LX Bedding Dispenser***

### **APPLICATION:**

The Bedding Dispenser is a semi-automatic unit designed to dispense bedding materials into two (2) rodent cages (maximum 13" x 13") simultaneously when they are placed into position within the filling area. The dispenser is capable of handling most chip-type, free flowing solid bedding, as commonly used in the animal care industry. The dispensed bedding volume is adjustable to accommodate various depths and sizes of cages.

### **STANDARD FEATURES:**

- All Stainless Steel Construction
- 15 Cubic Feet Bedding Hopper
- Automatic Bedding Transfer
- Operator Control Panel
- Stainless Steel Work Station
- Dust Filtration

### **OPTIONAL FEATURES:**

- Dust Collection System
- Air Compressor
- Seismic Tie Down



### **SIZE:**

**Tunnel Opening:** 14" high x 27" wide

**Overall Size:** 93" high x 43" wide x 30" long

***Make a Difference...Make it LYNX!***

## Utilities: 710LX

E	Electrical	120 VAC	Single Phase	60 Hz	30 Amps
V	Vent	4" ID Duct	650 CFM	¾" SP	

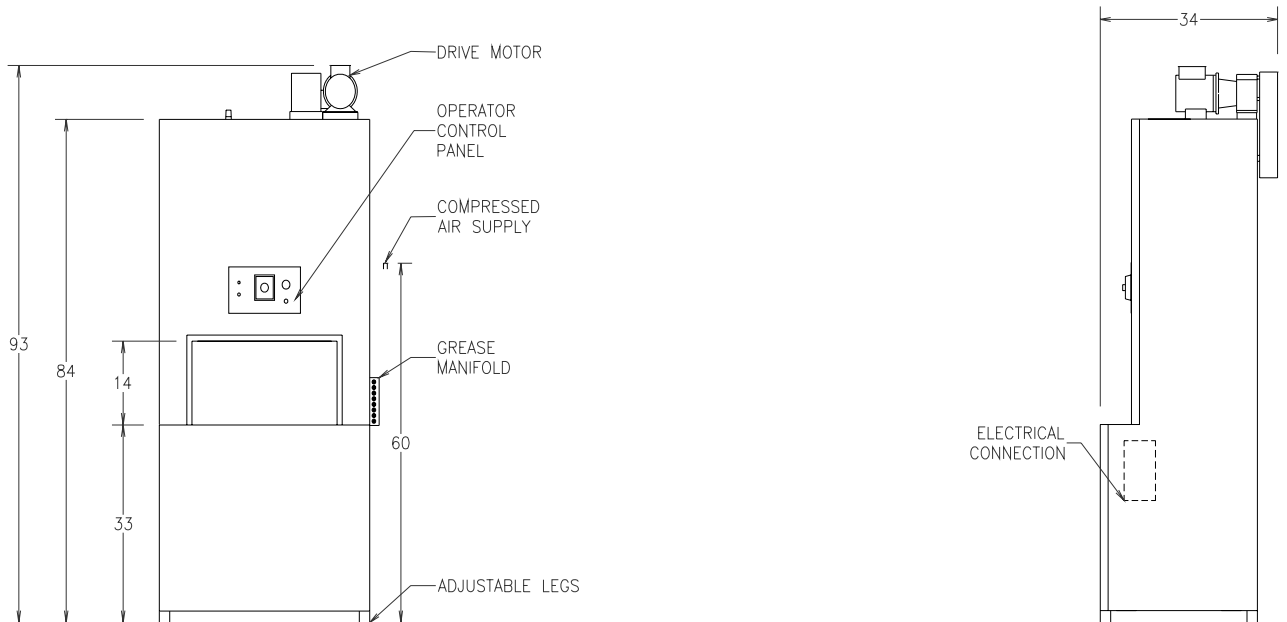
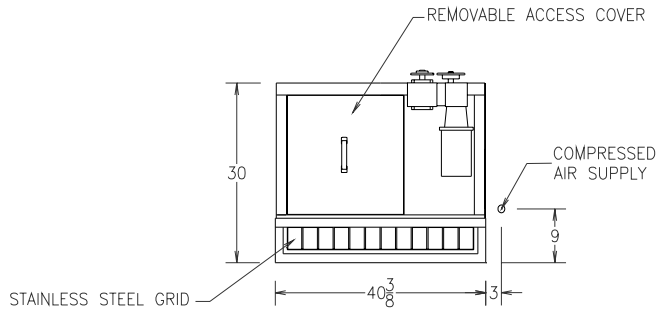

### NOTE:

- The selection of certain options could reduce the above stated utilities. Please consult your LYNX representative to discuss your specific requirements.
- Drawing data is for general reference only. Each sized unit and selected options will effect the overall machine size. Obtain certified drawings for design and installation details.
- Specifications are subject to change without notice.