

# MODEL 724LX

## BEDDING DISPENSER



## MODEL 724LX

The LYNX Model 724LX Bedding Dispenser is an automatic, conveyORIZED unit designed to automatically dispense most solid bedding materials\* into animal cages as they are conveyed through the filling chamber. The bedding volume is adjustable to accommodate various bedding depths and sizes of cages.

### STANDARD FEATURES:

- 12 Cubic Foot Bedding Hopper
- Load-end Water Collection Tank
- Cleanout Access Ports
- Operator Control Panel
- Adjustable Bedding Fill Volume

### CONSTRUCTION:

- All 304 Stainless Steel Construction
- Powered Stainless Steel Rollers
- Designed for Left or Right Hand Controls and Hopper Access

### OPTIONAL FEATURES:

- Standard Dust Collection System
- Premium Dust Collection System
- Knock-down Shipment
- Photo-electric Conveyor Stop
- Seismic Tie-down
- Discharge Roller Conveyor
- Extended Powered Discharge Conveyor
- Bedding Fill Funnel/Transfer System

\* Equipment designed for free-flowing and non-bridging bedding. Please consult the factory for all other bedding.



### Size:

Tunnel Opening:  
12" high x 30" wide

Overall Unit:  
67" high x 74" wide x 96" long

**700**  
SERIES

E	Electrical	40A – 110V	
D	Drain	2" Floor Drain	
V	Vent	4" ID Duct	650 CFM

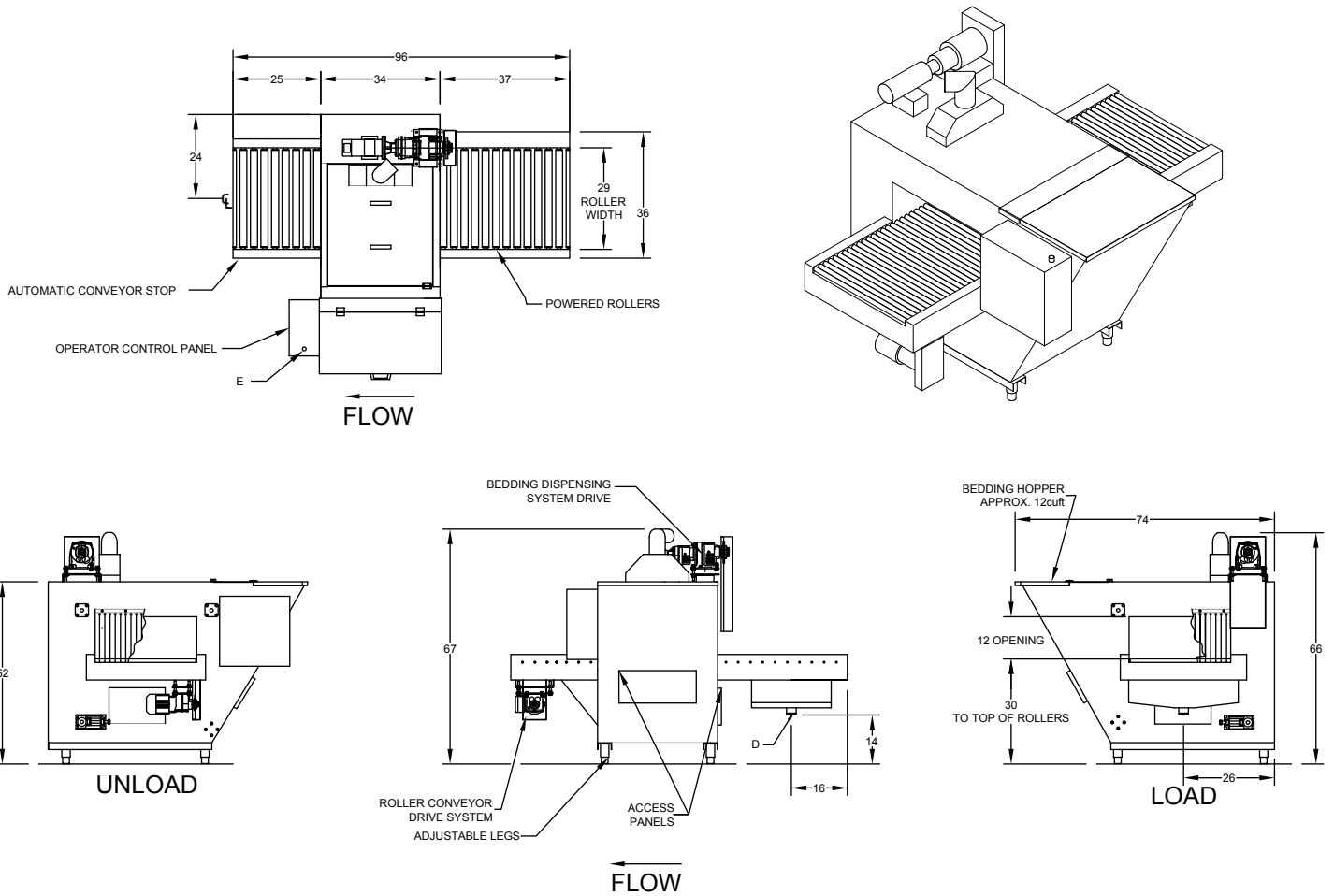

For further information, please contact: